

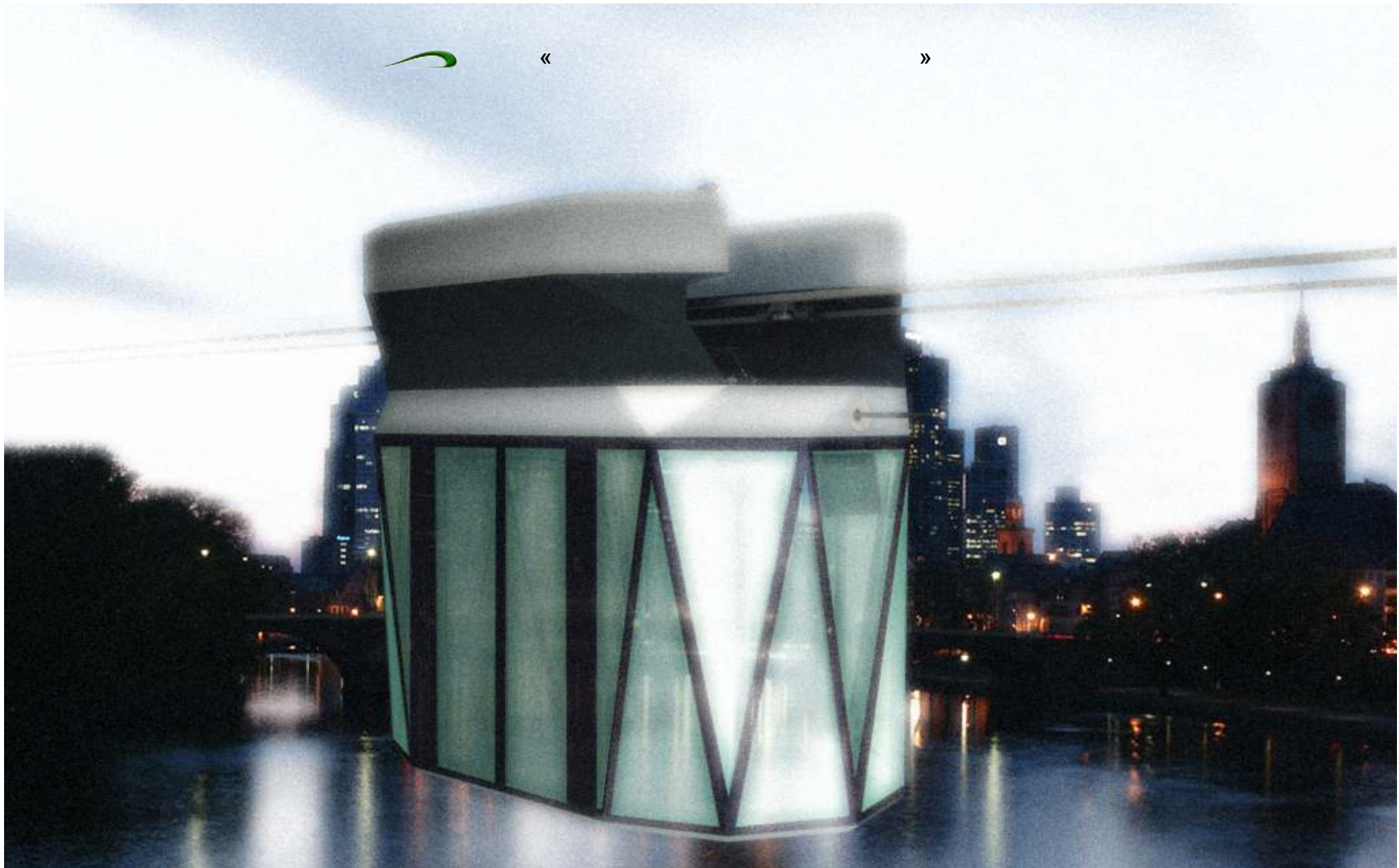

«

»



2009

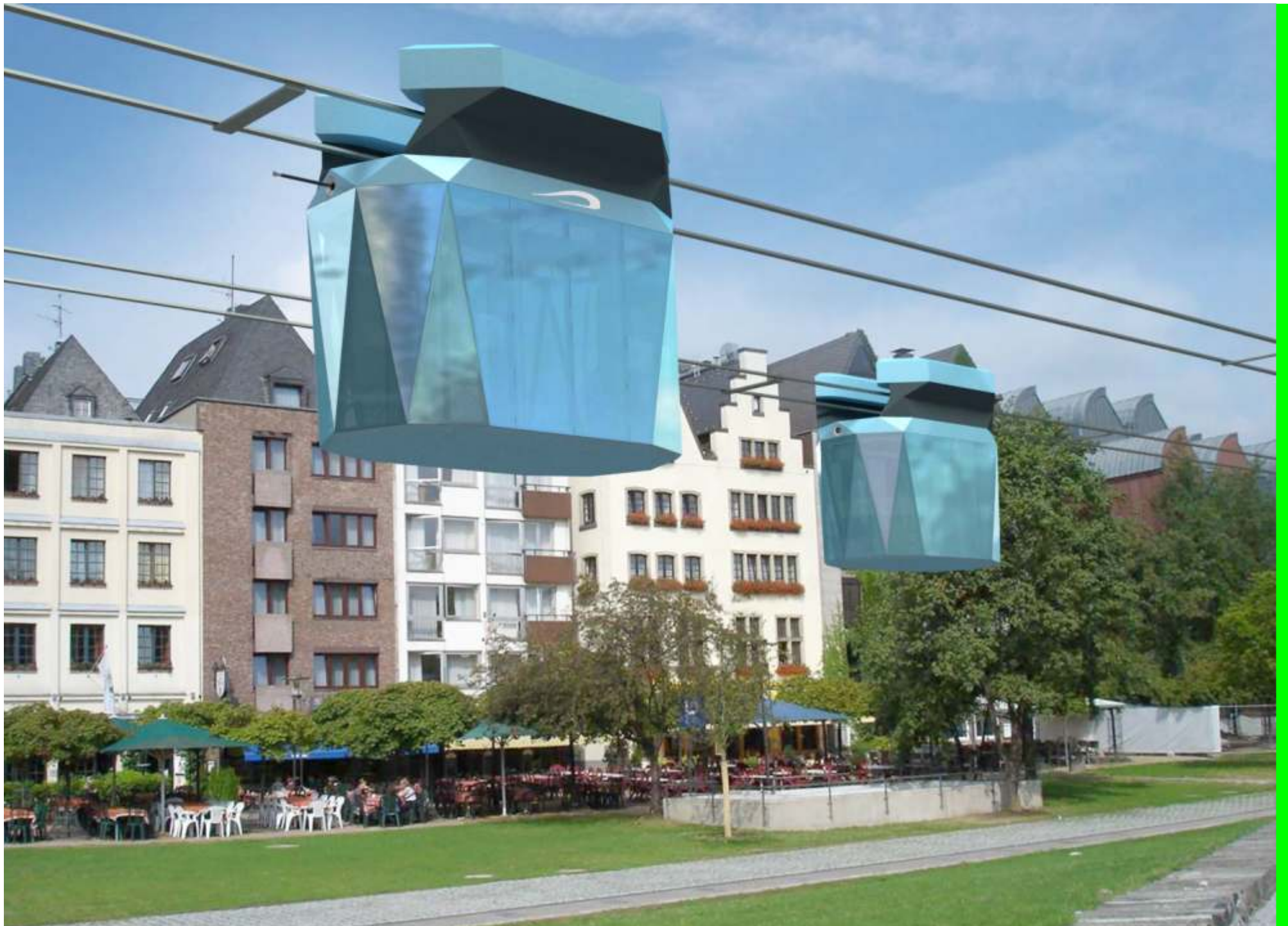

1		20 ( 8 )
2	,	3300
3	,	4800
4	- - - - -	4000 2450 3700 1800 1250
5	, /	60
6		4 4
7	( - 10 .): - /100 - /100 . ( - )	700 1330 0,4



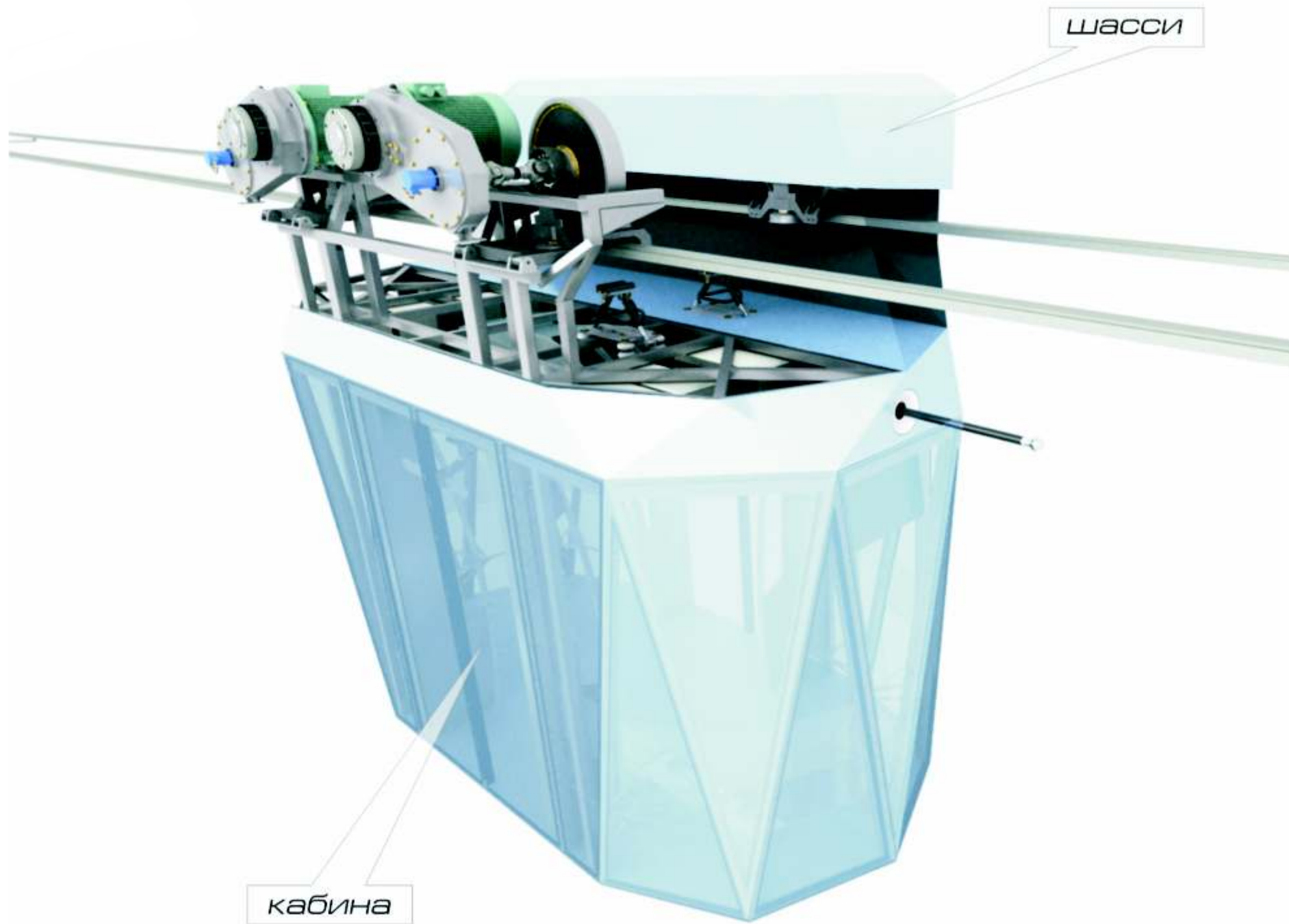

шасси

кабина

тяговый преобразователь

тяговый электродвигатель

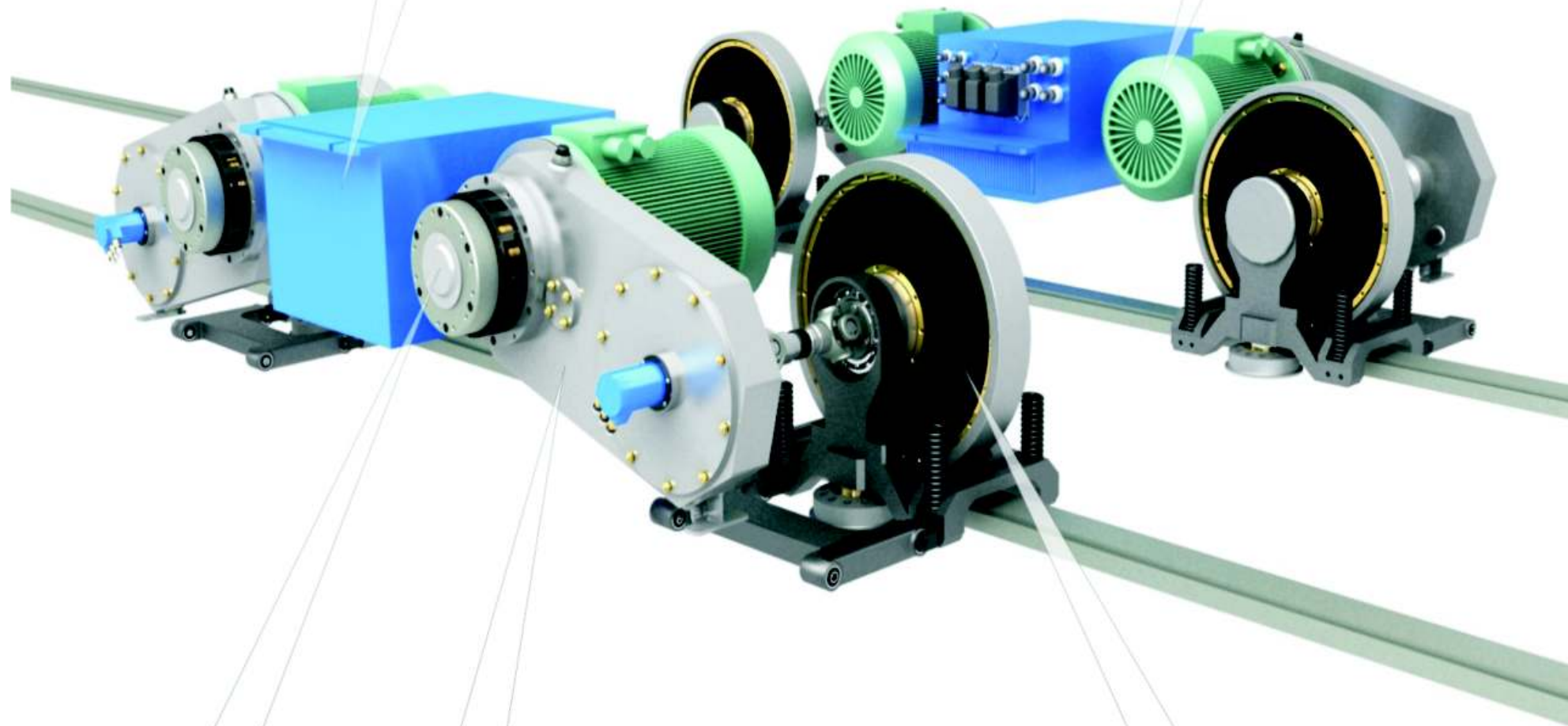

тормоз

редуктор

ходовой блок

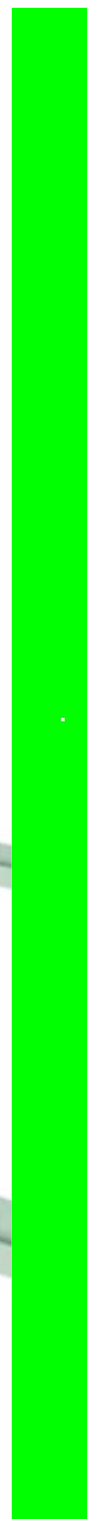

ТОКОСЪЕМ ЗАРЯДКИ

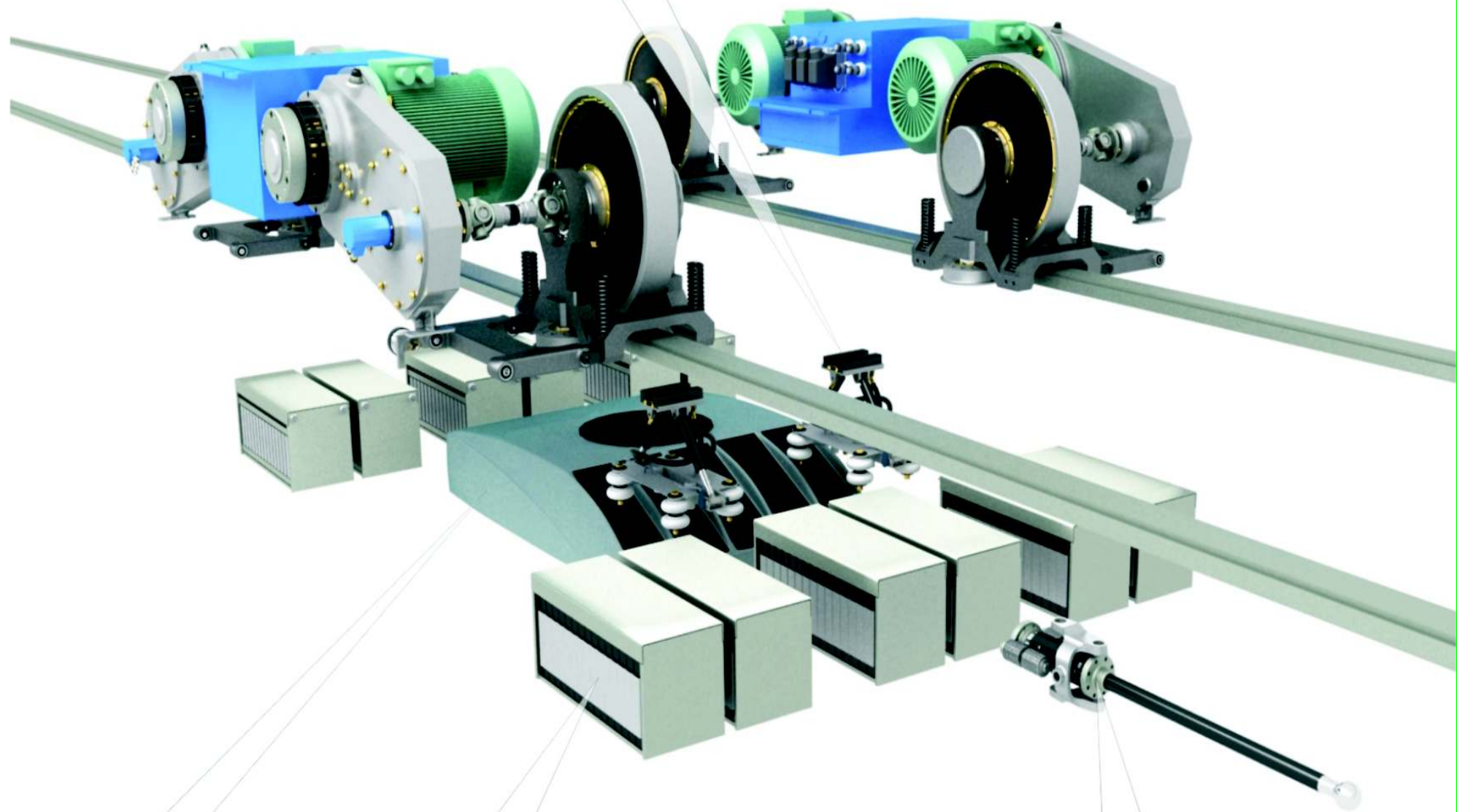

КОНДИЦИОНЕР

НАКОПИТЕЛИ ЭНЕРГИИ

СТЫКОВОЧНОЕ УСТРОЙСТВО

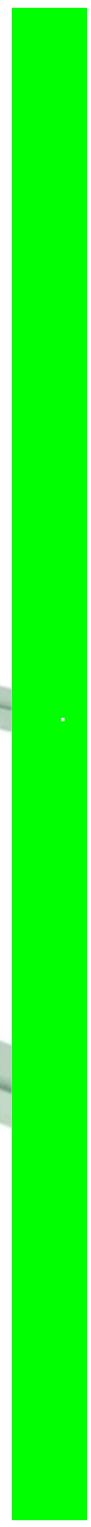

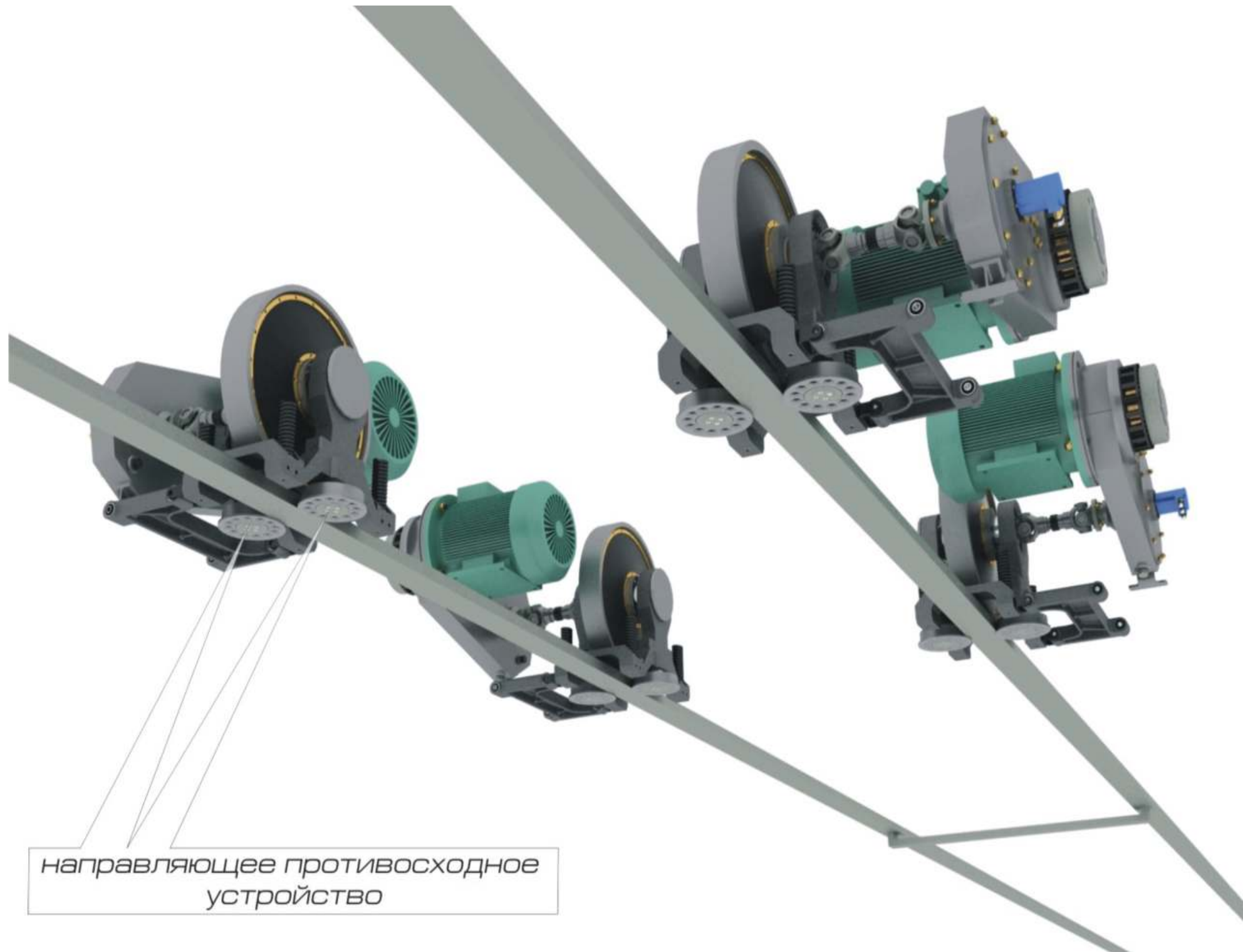

направляющее противосходное  
устройство

